

STAINLESS STEEL JIC TYPE 4X CLAMP COVER - LESS PANEL

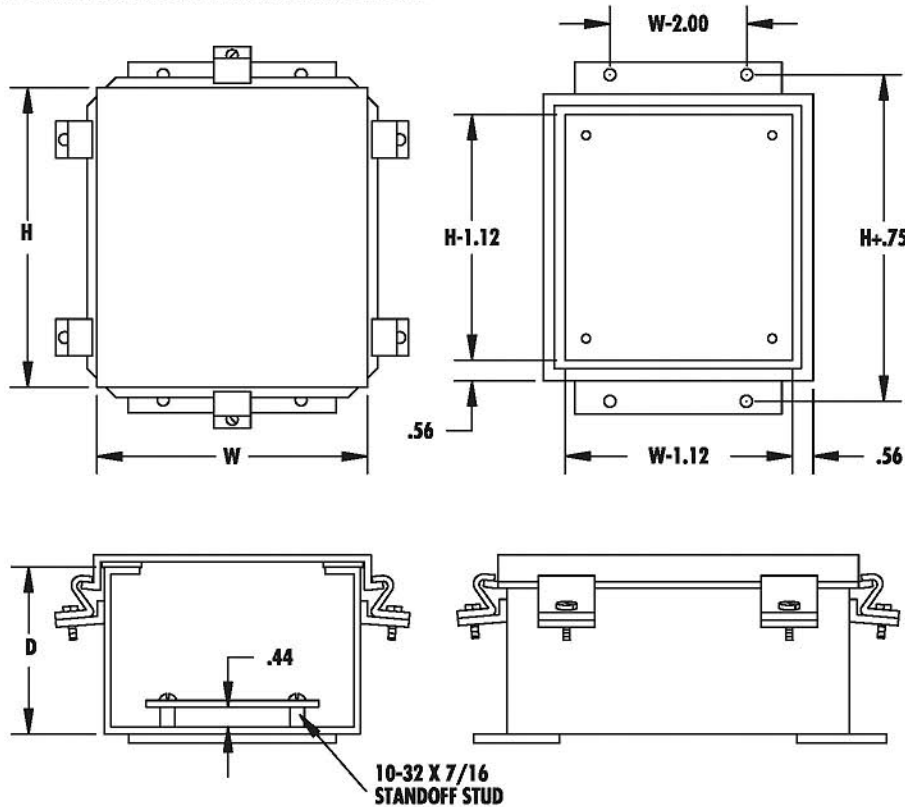

NOTE: MAXIMUM SPACING BETWEEN CLAMPS IS 8.00.



CONSTRUCTION:

- CODE GAUGE TYPE 304 STAINLESS STEEL
- SEAM CONTINUOUSLY WELDED AND GROUND SMOOTH
- STAINLESS STEEL SCREWS AND CLAMPS ON FOUR SIDES OF COVER ASSURE WATERTIGHT SEAL
- OIL RESISTANT GASKET
- ALSO MEETS INDUSTRY STANDARDS FOR TYPE 12 USE

FINISH:

- ENCLOSURES HAVE A BRUSHED FINISH

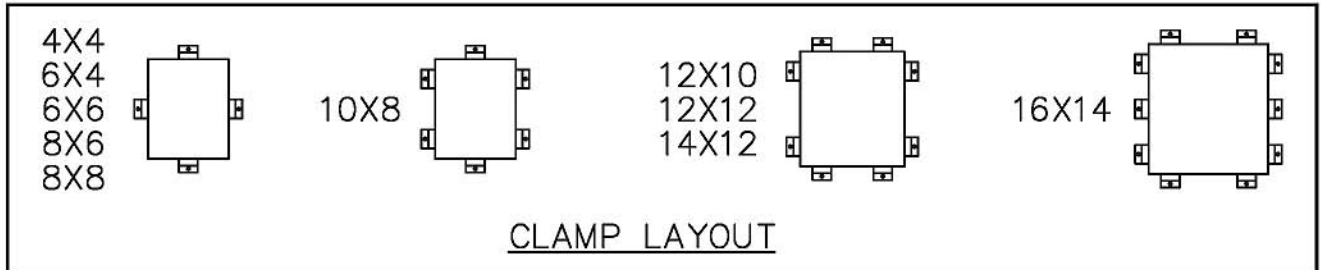

TYPE 4X

STAINLESS STEEL JIC TYPE 4X CLAMP COVER			STEEL PANEL (WHITE)	
Enclosure Size HxWxD	Catalog Number	Weight	Catalog Number	Weight
4x4x3	SJCC443	8	N/A	N/A
6x4x4	SJCC644	4	64PJ	1
6x6x4	SJCC664	4	66PJ	1
8x6x4	SJCC864	6	86PJ	1
10x8x4	SJCC1084	9	108PJ	1
12x10x6	SJCC12106	15	1210PJ	2
14x12x6	SJCC14126	17	1412PJ	3
16x14x6	SJCC16146	21	1614PJ	5

NOTE: FOR QUICK RELEASE LATCHES SEE ACCESSORIES SECTION

NOTE: For 316L Stainless Steel add "-6" to catalog number.