

CATALOG#: DFN12

UL LISTED

CANADIAN UL LISTED

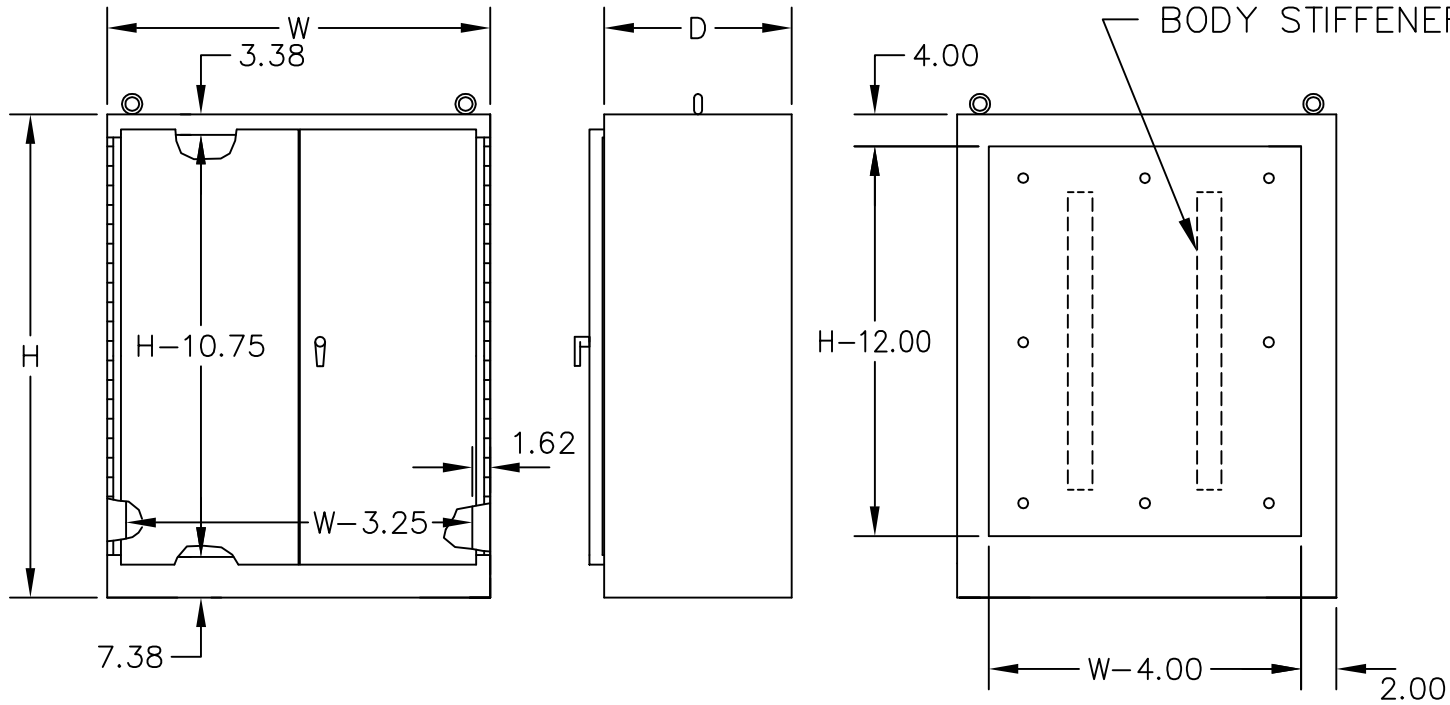

TWO DOOR FREE STANDING TYPE 12

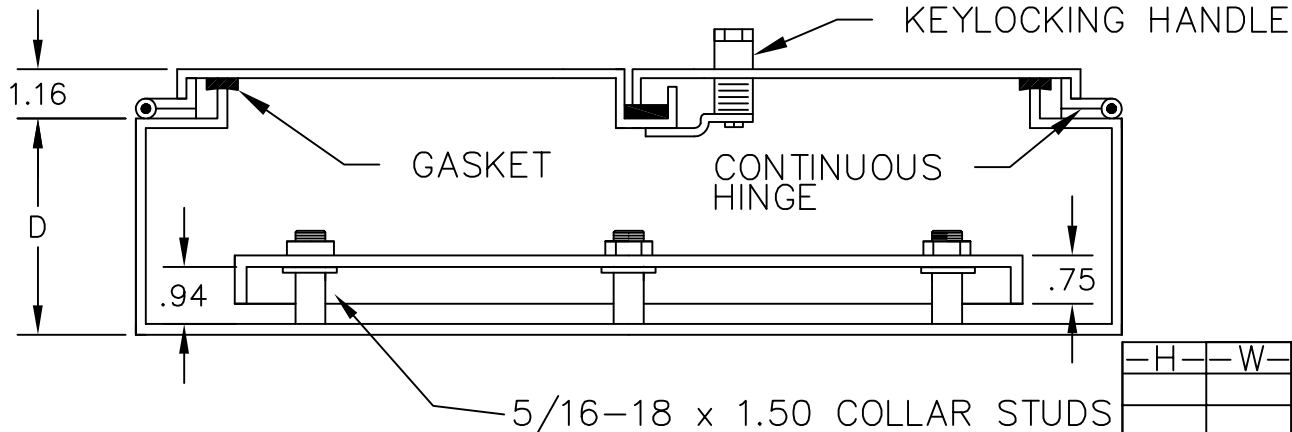

CONSTRUCTION:

- 12 GAUGE STEEL
- SEAMS CONTINUOUSLY WELDED AND GROUND SMOOTH.
- GASKETED OVER-LAPPING DOORS ELIMINATE NEED FOR CENTER POST.
- 3-POINT LATCHING MECHANISM OPERATED BY OIL-TIGHT KEYLOCKING HANDLE.
- LATCH RODS HAVE ROLLERS FOR EASIER DOOR CLOSING.
- HEAVY GAUGE CONTINUOUS HINGE.
- HEAVY-DUTY LIFTING EYES.
- OIL RESISTANT GASKET.
- OPTIONAL UNI-STRUTS OR STUDS PROVIDED FOR MOUNTING OPTIONAL PANEL.

FINISH:

- ANSI 61 GRAY POLYESTER POWDER COATING INSIDE AND OUT.

APPROVAL:



E-BOX
 101 Air Park Industrial Road
 Alabaster, Alabama 35007
 Phone: (205)663-9189
 Fax: (205)663-9587



H	W	D