

CATALOG # TCF

UL LISTED

CANADIAN UL LISTED

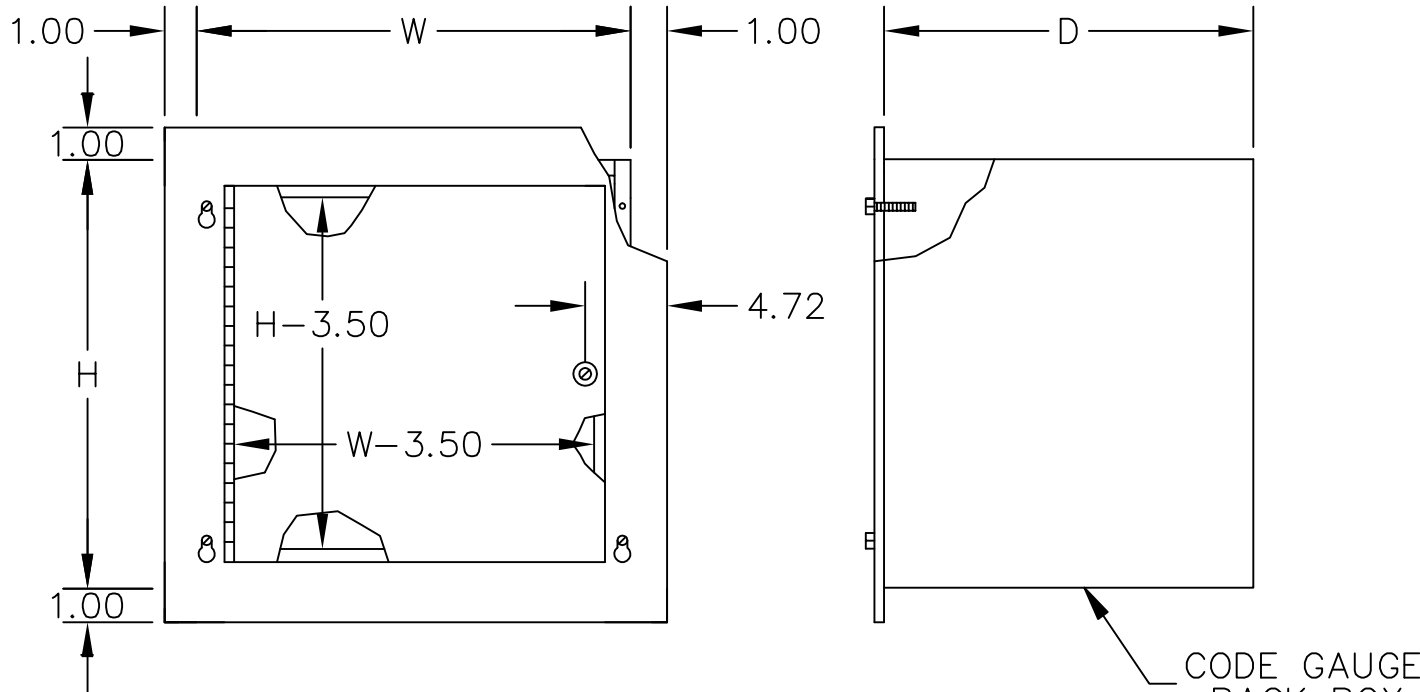

TYPE 1 TELEPHONE CABINETS

CODE GAUGE BACK BOX

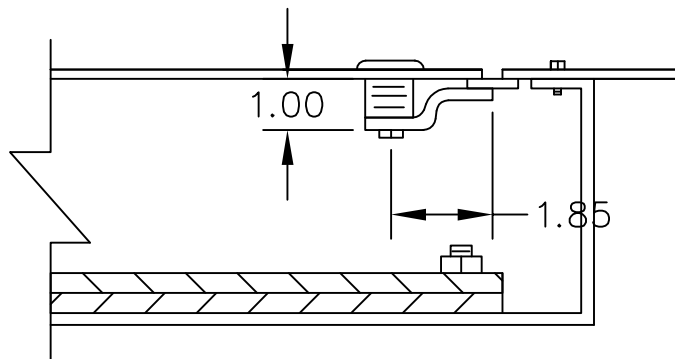
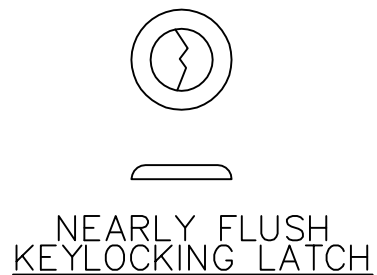

FLUSH MOUNT

CONSTRUCTION:
 -CODE GAUGE PAINT GRIP GALVANIZED STEEL.
 -REMOVABLE TRIM.
 -CONTINUOUS HINGE.
 -OPTIONAL 3/4 PLYWOOD PANEL.
 -KEYHOLE SCREW SLOTS IN THE COVER PERMIT THE REMOVAL OF THE COVER WITHOUT EXTRACTING THE SCREWS.

FINISH:
 -CABINETS ARE FURNISHED STANDARD WITH AN ANSI 61 GRAY POLYESTER POWDER COATED TELEPHONE FRONT AND A GALVANIZED BACK BOX.

-H-	-W-	-D-

APPROVAL:



E-BOX
 101 Air Park Industrial Road
 Alabaster, Alabama 35007
 Phone: (205)663-9189
 Fax: (205)663-9587

