

CATALOG#: SSG

UL LISTED

CANADIAN UL LISTED

NOTE: THE MAXIMUM DISTANCE BETWEEN SCREWS IS 12.25".

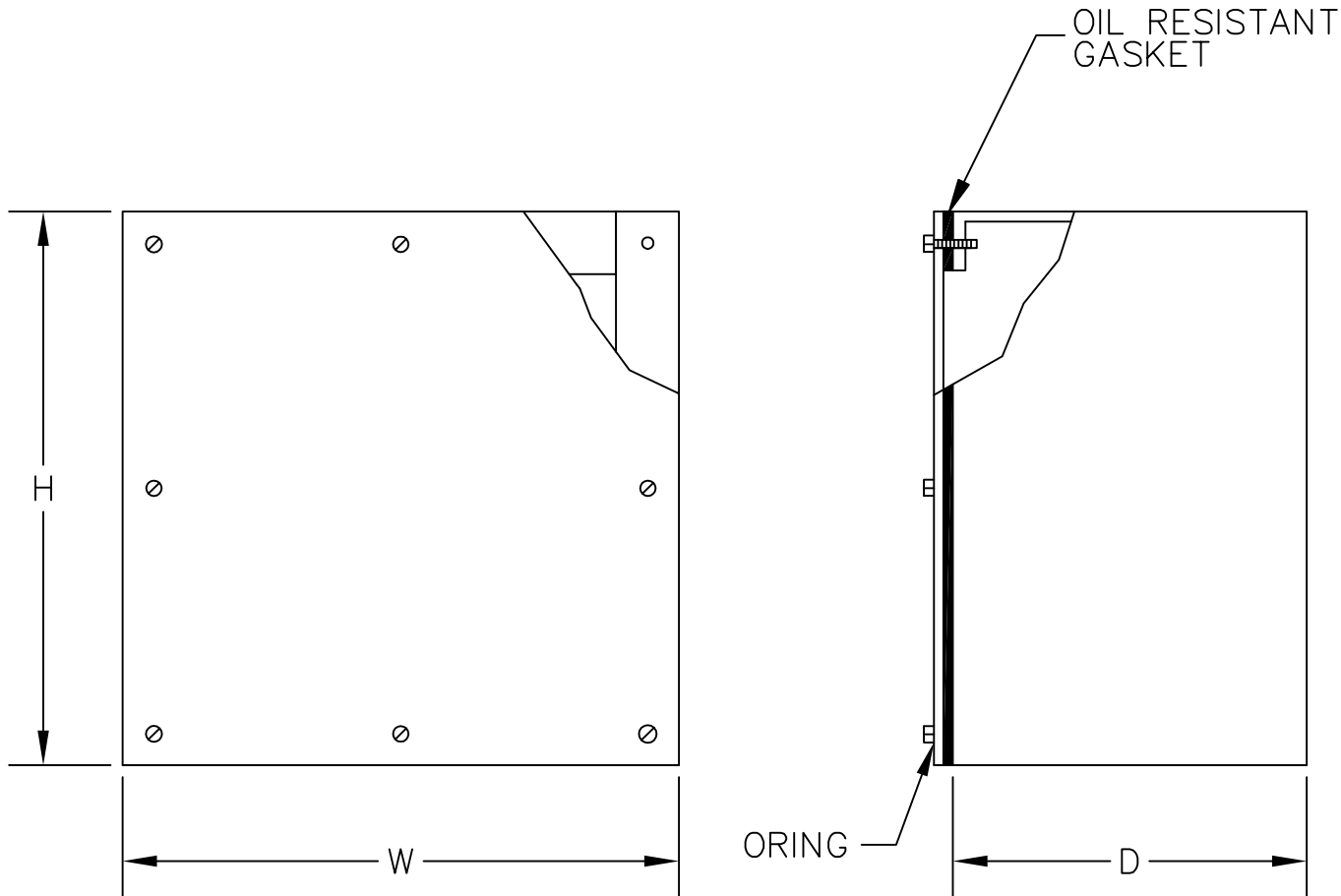

CONSTRUCTION:
 -CODE GAUGE TYPE 304 STAINLESS STEEL.
 -SEAMS CONTINUOUSLY WELDED AND GROUND SMOOTH.
 -REMOVABLE COVER FASTENED WITH STAINLESS STEEL SCREWS.

FINISH:
 -ENCLOSURES ARE UN-PAINTED AND HAVE A SMOOTH BRUSHED FINISH.

H	W	D

APPROVAL: _____

STAINLESS STEEL TYPE 3 AND TYPE 12 GASKETED SCREW COVER



E-BOX
 101 Air Park Industrial Road
 Alabaster, Alabama 35007
 Phone: (205)663-9189
 Fax: (205)663-9587

