

CATALOG#: FN4

UL LISTED

CANADIAN UL LISTED

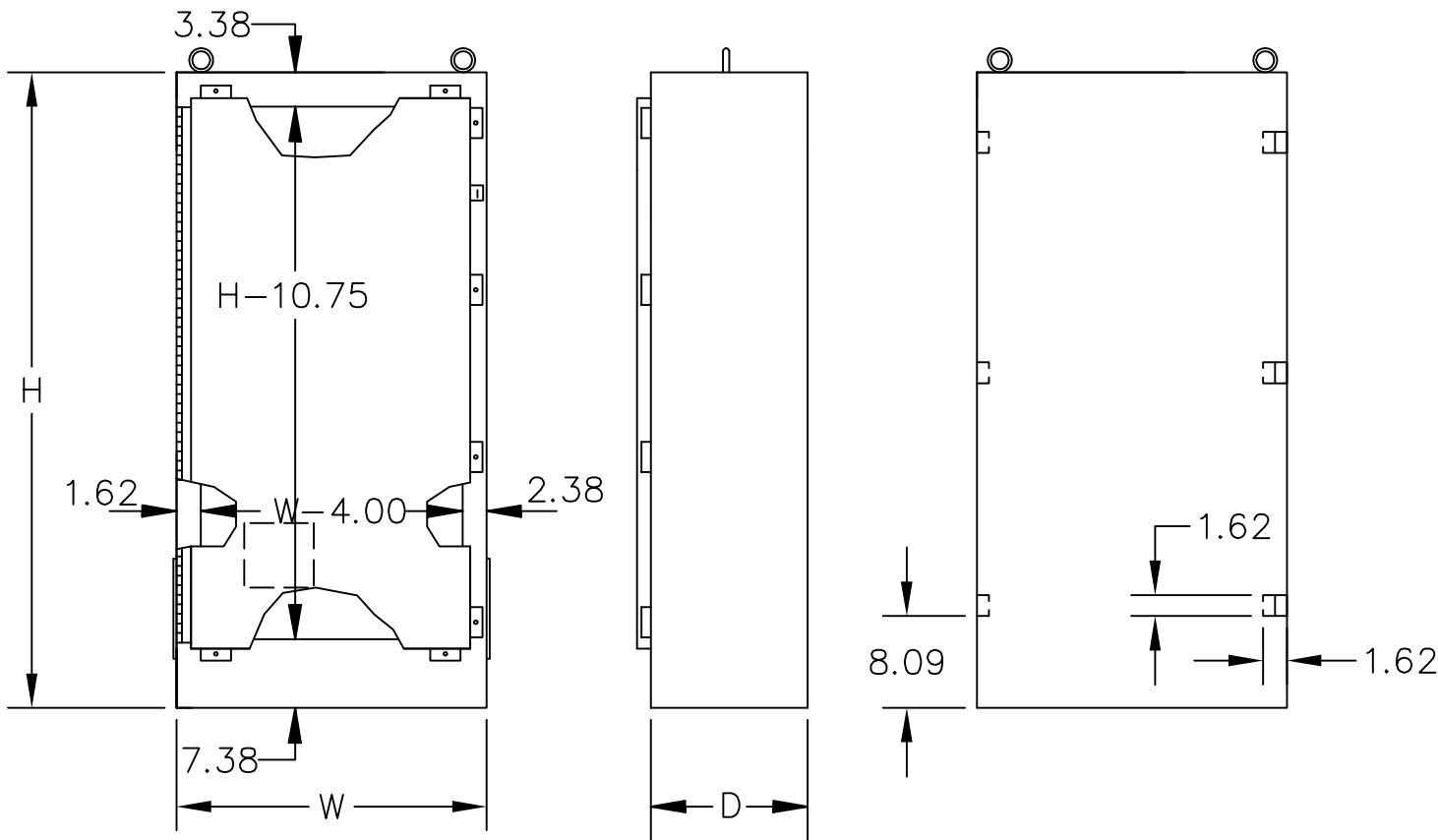

FREE STANDING TYPE 4 ENCLOSURES

CONSTRUCTION:

- 12 GAUGE STEEL.
- SEAMS CONTINUOUSLY WELDED AND GROUND SMOOTH.
- DOOR CLAMPS ON THREE SIDES OF DOOR ASSURE WATERTIGHT SEAL.
- HEAVY GAUGE CONTINUOUS HINGE.
- TONGUE AND HASP PROVIDED FOR PADLOCKING.
- REMOVABLE PRINT POCKET.
- LIFTING EYES FOR EASY HANDLING.
- OIL-RESISTANT DOOR GASKET.
- UNI-STRUT PROVIDED FOR MOUNTING OPTIONAL PANEL.

FINISH:

- ANSI 61 GRAY POLYESTER POWDER COATING INSIDE AND OUT.

H	W	D

APPROVAL:



E-BOX
 101 Air Park Industrial Road
 Alabaster, Alabama 35007
 Phone: (205)663-9189
 Fax: (205)663-9587

