

CATALOG#: JHN4

UL LISTED

CANADIAN UL LISTED

NOTE: MAXIMUM SPACING BETWEEN CLAMPS IS 8.00.

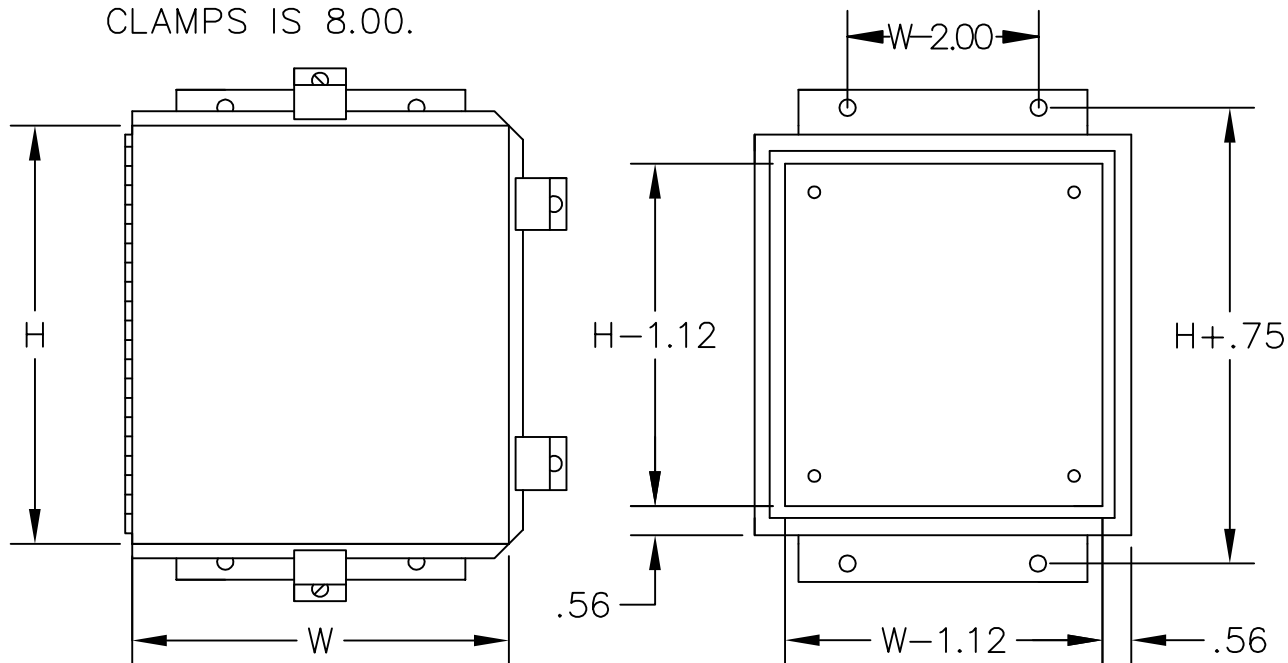

JIC HINGE COVER TYPE 4

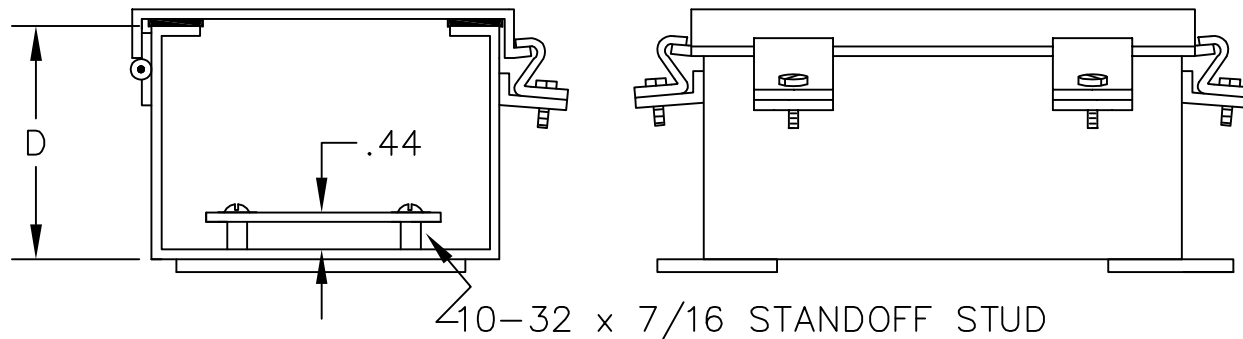

10-32 x 7/16 STANDOFF STUD

CONSTRUCTION:
 - CODE GAUGE PAINT GRIP GALVANIZED STEEL.
 - SEAMS CONTINUOUSLY WELDED AND GROUND SMOOTH.
 - CLAMPS ON THREE SIDES OF COVER ASSURE WATER-TIGHT SEAL.
 - CONTINUOUS HINGE.
 - OIL-RESISTANT GASKET.
 - OPTIONAL PANEL.

FINISH:
 - ANSI 61 GRAY POLYESTER POWDER COATING INSIDE AND OUT.

-H-	-W-	-D-

APPROVAL: _____



E-BOX
 101 Air Park Industrial Road
 Alabaster, Alabama 35007
 Phone: (205)663-9189
 Fax: (205)663-9587

