

CATALOG#: SJCCN4X

UL LISTED

CANADIAN UL LISTED

NOTE: MAXIMUM SPACING BETWEEN CLAMPS IS 8.00.

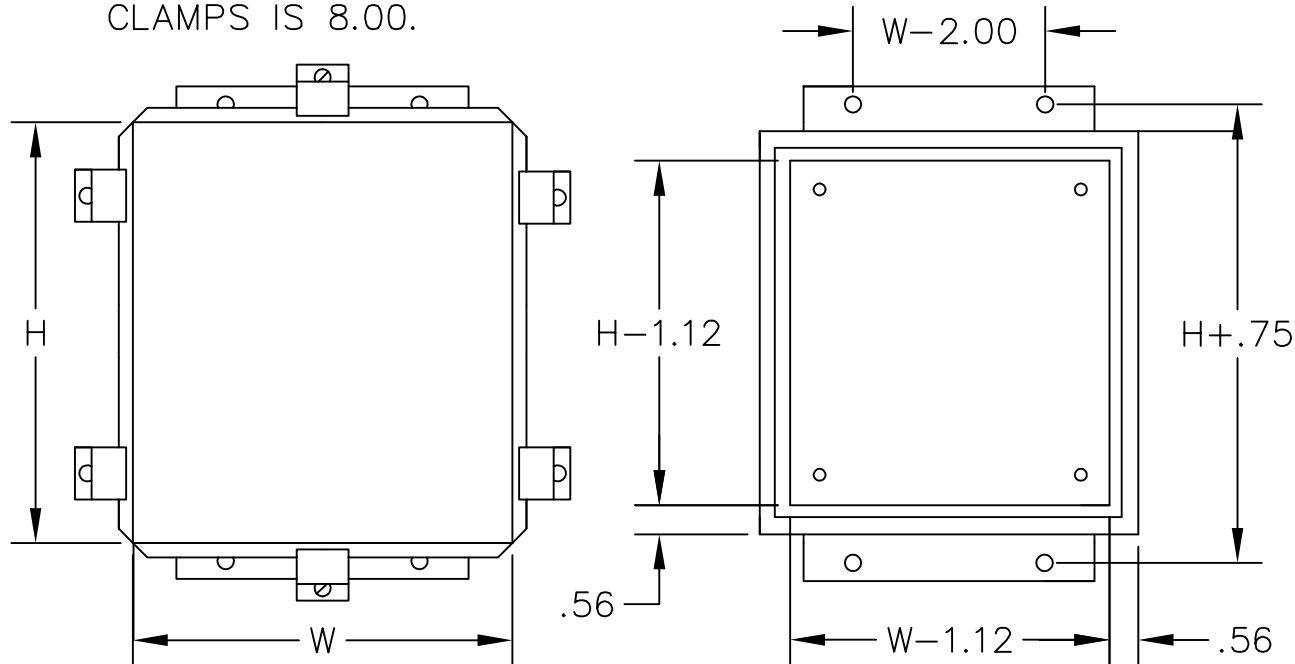

STAINLESS STEEL CLAMP COVER TYPE 4X

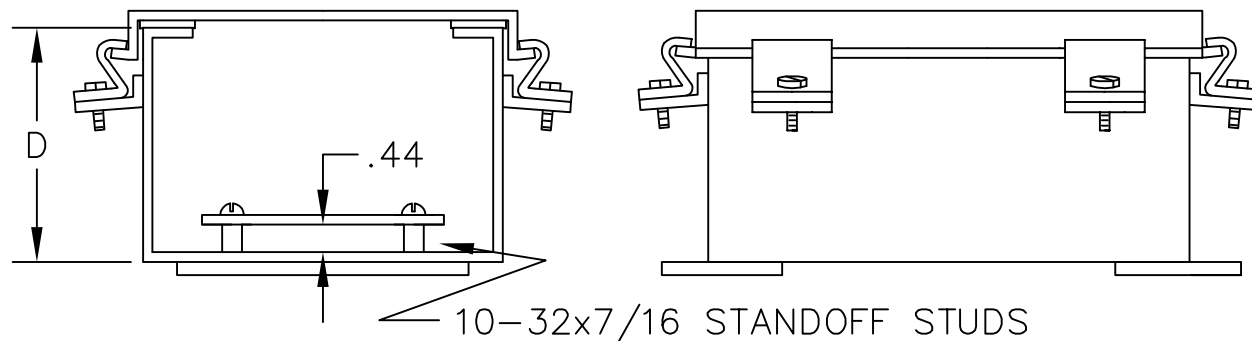

10-32x7/16 STANDOFF STUDS

CONSTRUCTION:

- CODE GAUGE TYPE 304 STAINLESS STEEL.
- SEAMS CONTINUOUSLY WELDED AND GROUND SMOOTH.
- STAINLESS STEEL SCREWS AND CLAMPS ON FOUR SIDES OF COVER ASSURE WATER-TIGHT SEAL.
- OIL-RESISTANT GASKET.

FINISH:

- ENCLOSURES ARE UNPAINTED AND HAVE A NUMBER 3 SMOOTH BRUSHED FINISH.

-H-	-W-	-D-

APPROVAL:



E-BOX
 101 Air Park Industrial Road
 Alabaster, Alabama 35007
 Phone: (205)663-9189
 Fax: (205)663-9587

